

Conveyors Plus, Inc.
www.conveyorsplus.com

Right Angle Plate Transfer Assembly

Third Generation

Model Quantum 2K

- Couples plate exposing units to processors for a complete 100% hands free plate transport system
 - Transports plate sizes 41" x 31.5" to 15" x 12"
 - On demand performance
 - Simplistic design
 - Right or Left hand flow assemblies
 - Aluminum extruded support frame
 - Self contained circuit protection
 - Field proven performance
 - Easy setup - 100% dependable
 - Compact foot print
 - Versatile - Install anywhere in processing line
 - Mar-resistant urethane conveying surfaces
-

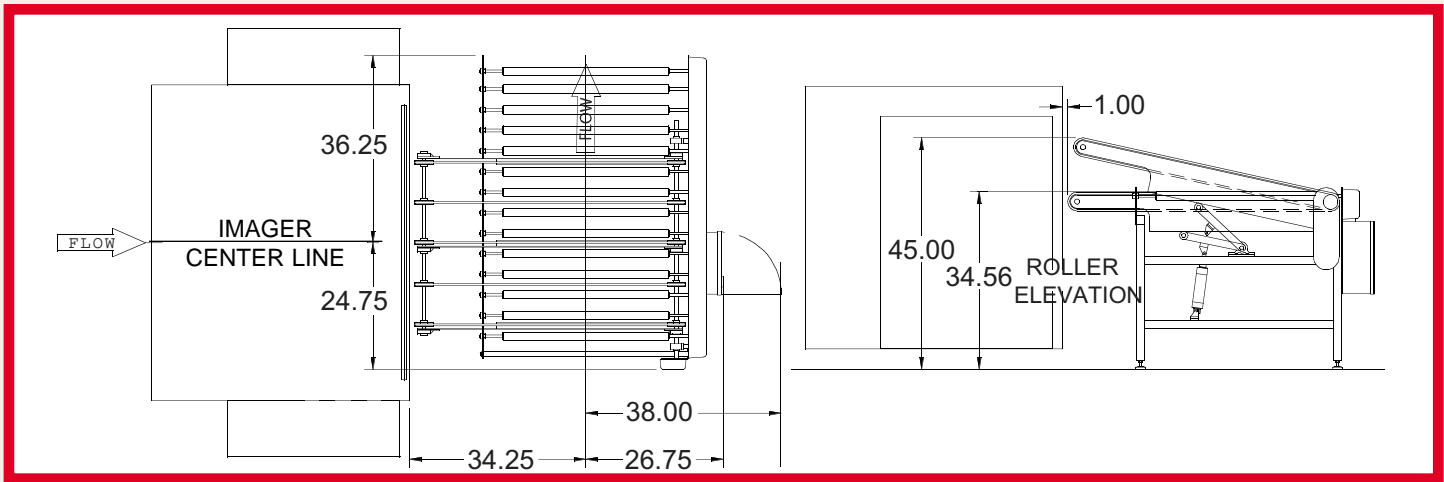

Right Angle Plate Transfer Assembly - Model Quantum 2K

NEW FEATURES

- Variable speed roller control
- Plate pick-up directly from plate exposing unit
- Plate exposing unit does not require an exit conveyor
- Height adjustments for various output devices

SPECIFICATIONS

- 61" wide x 61" long Right Angle Transfer Unit
- Stainless steel side frames
- Five urethane in-feed belts
- Pneumatic in-feed belt elevator actuator
- OSHA lockout air prep unit
- 1 5/8" Urethane covered conveyor rollers
- Variable speed control potentiometer
- Self contained electrical controls
- Adjustable floor supports
- Totally enclosed ABS drive guards
- 115V A.C. motor for in-feed belt speed of 15 F.P.M.
- 115V A.C. motor for roller speed of 1 to 7.6 F.P.M.
- Extended transport system (no need for plate setter exit conveyor)
- Maximum plate size = 41" x 31.5"
- Minimum plate size = 15" x 12"
- Unit weight 425 lbs. / Shipping weight 600 lbs.

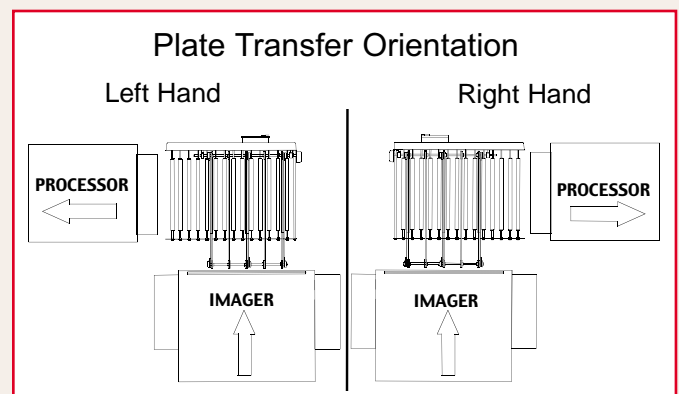

(Specify plate transfer orientation when ordering)

UTILITY REQUIREMENTS

- 115 VAC 5 AMPS
- Clean dry compressed air
- 0.1 SCFM @ 60 PSI

www.conveyorsplus.com

For Additional Information:
 Contact: Alan Cudahy
 Phone: 970-547-0005
 Fax: 970-547-8352
 E-Mail: conveyorsplus@comcast.net

 Conveyors Plus, Inc.
 13301 Southwest Highway
 Orland Park, IL 60462-1364

To order:
 Contact: Conveyors Plus, Inc.
 Phone: 708-361-1512
 Fax: 708-361-4372
 E-Mail: contact@conveyorsplus.net